



20kg Maximum
Payloads



8-12 pcs/min
Cycles



Easy to Deploy
in 30mins



One-Stop Palletizing Solution

Empower Your End-of-line Operations
and Boost Productivity

Why Dobot Palletizing Solution?

The Dobot Palletizing Solution is designed to make automation accessible, no professionals required. Dobot can accommodate all of your diverse needs with its plug-and-play palletizing solution. The Dobot Process Package is easy-to-use, no programming required for re-configuration, reducing subsequent maintenance costs.



Food & Beverages



Pharmaceutical



Cosmetics



Consumer Goods

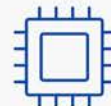

Electronics



Household Appliances

High Payload and Speed:

The workstation supports up to 20kg and stacks to 2100mm, suitable for food, beverage, and pharmaceutical industries, with palletizing speeds of 8-12 pieces per minute using the latest CR20A cobots.



Quick Deployment:

Dobot's integrated solution allows for production setup in just 30 minutes with a simple 4-step procedure, eliminating the need for programming.



Flexibly Switch Between Production Lines:

Frequent changes between production lines can make traditional industrial robots hard to reconfigure and often require specialized support. In contrast, the portable Dobot Palletizing Workstation enables quick switching between lines anytime and anywhere.



Safe Human-Robot Collaboration:

Features like virtual walls and compatibility with external safety devices ensure safe operations, backed by multiple safety certifications.



Product Snapshot



**One Workstation,
Multiple Production Lines**

Quick Palletizing & Depalletizing

20+ Safety Certifications

**CE, SGS Listed Mark, FCC,
ICES-003 Certifications**

1 Dobot CR20A Cobot

2 Lifting Axis

**3 Columnar & Lift
Palletizing Workstation**

4 Standard Palletizing Base

**5 Pallet Detection and
Positioning Device**

**6 End-effector Vacuum
Suction Tools (Optional)**

7 External Terminal Panel

Automation is Here, Explore with Dobot 3D Palletizing Simulation

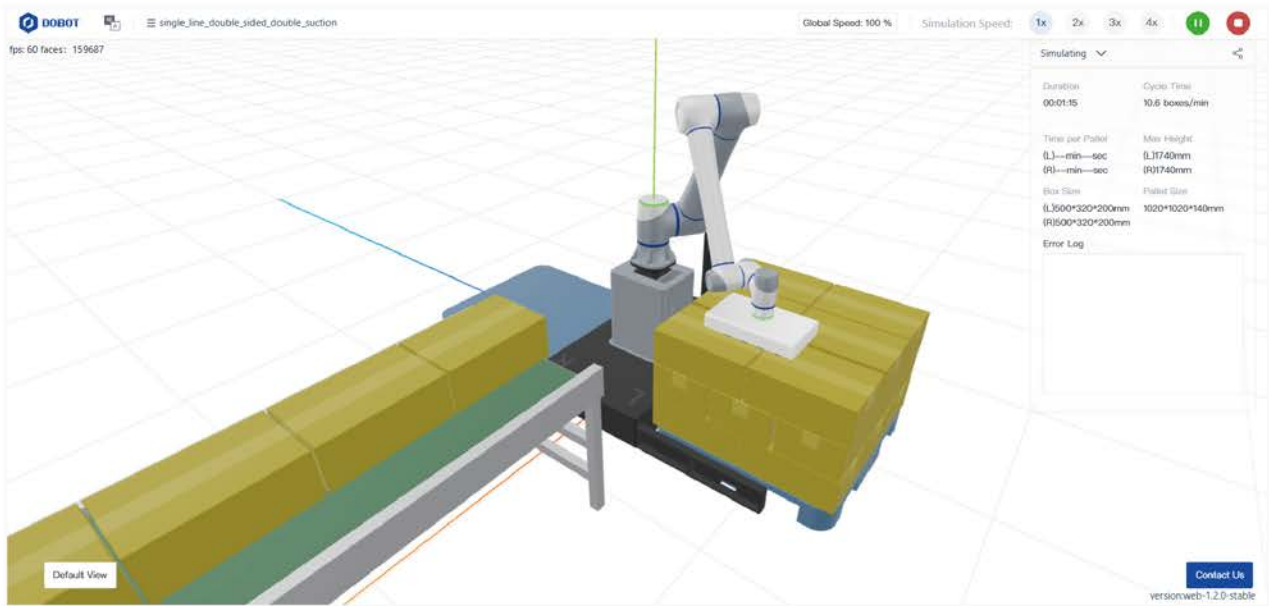

Easy to Set up with Dobot Palletizing Process Package

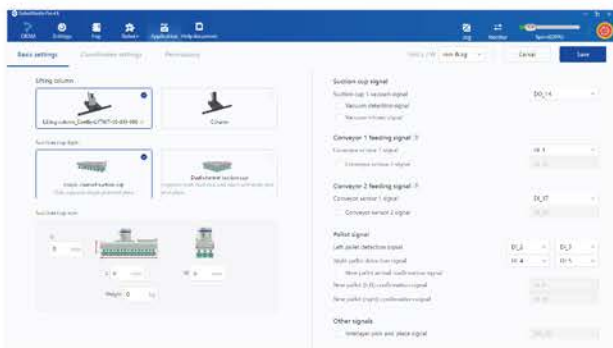

Step 1: Set up the workstation specifications



Step 2: Set up the box and pallet

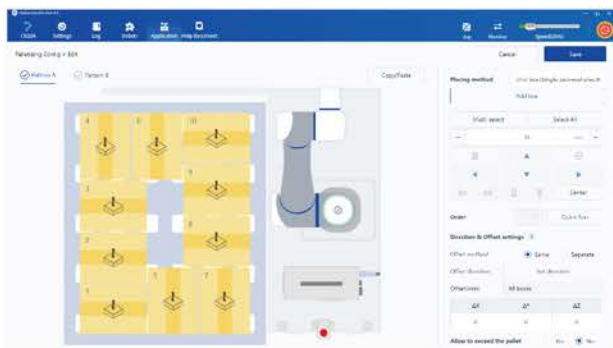

Step 3: Pallet type configuration

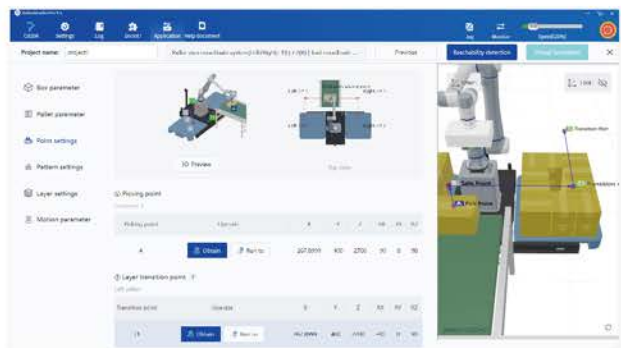

Step 4: Picking points configuration

Diverse Functions to Boost the Efficiency

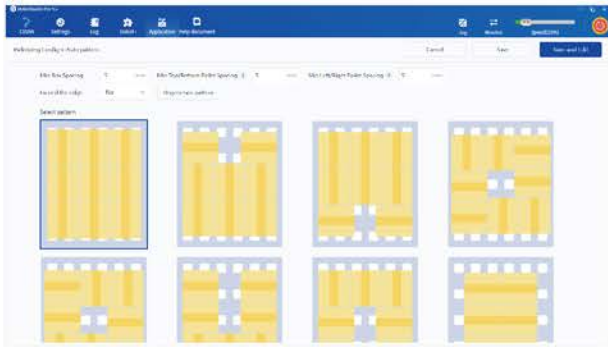

Auto-Generation for Palletizing Patterns

The algorithm automatically generates various palletizing patterns based on user-defined pallet and box sizes. Users can choose and further fine-tune their selections, quick to achieve the wanted palletizing patterns in 2 mins, greatly improving editing efficiency.

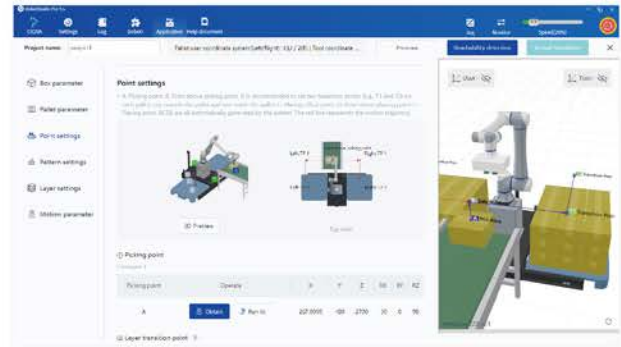

Easy to Plan Cobot's Action Trajectory

The drag-and-drop point teaching allows the robot to automatically plan the most efficient action trajectory.

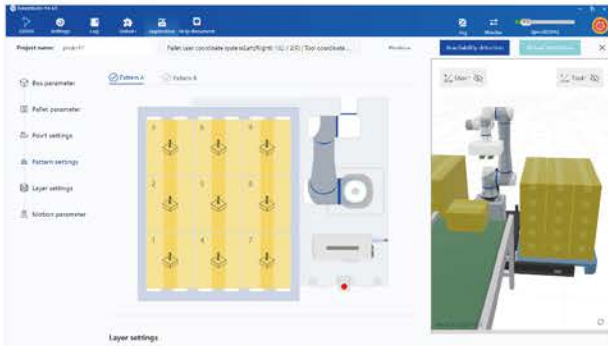

3D Palletizing Simulated Software Platform

The Dobot Simulated Software Platform allows users to simulate real-time automated palletizing effects and evaluate workflow efficiency. It accurately models pallet and box dimensions and replicates the deployment and functionality of real-world solutions.

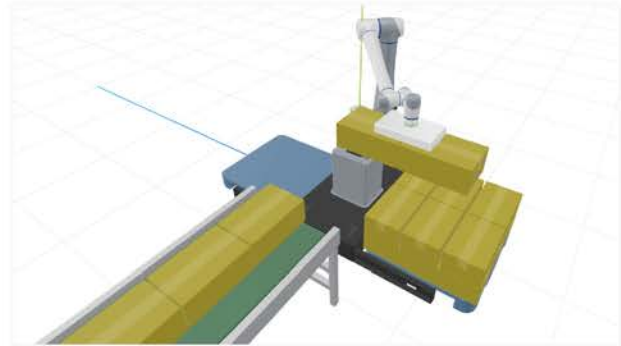

Efficient Dual-suction Mode

The dual and single suction cup modes allows for flexible configuration. When dealing with complex pallet arrangements that cannot be managed with dual suction, it can be configured to pick and release one box at a time or to handle two boxes simultaneously.

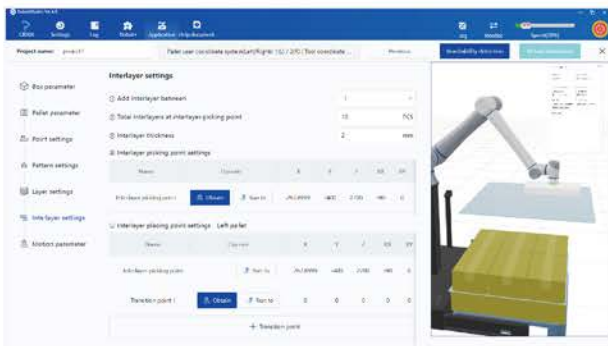

Supports Easy Plug-in of Interlayer

Increase the stability of palletizing.

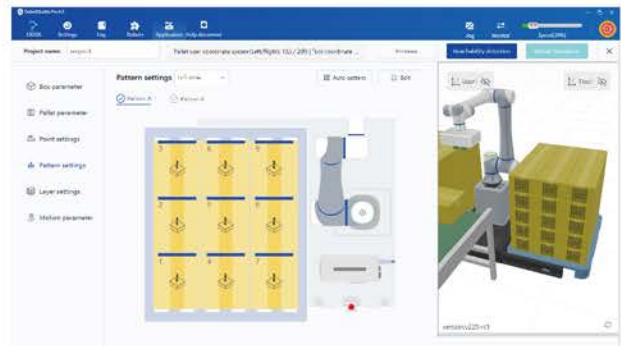

Label Function

With fixed product and label orientations, the label function allows users to control the label direction of products within the stacking pattern.

Product Specifications

Product Name	CR20A Columnar Palletizing Workstation	CR20A Lifting Palletizing Workstation
Max Payload *1	20 kg	
Max Palletizing Pace *2	8-12pcs/min	
Max Palletizing Height *3	1740 mm	2100 mm
Working Radius	1700 mm	
Footprint	1350 mm * 2260 mm	
Net Weight *4	350 kg	
Rated Voltage	AC 100-240V 50/60Hz	
Max Current	13A	
Temperature Range	10°C-40°C	
Protection Level	Robot Arm: IP54; Palletizing Workstation: IP20	
Certifications	EU: CE CAN&US: SGS Listed Mark,FCC, ICES-003	
*1. Self-weight excluding end effector.		
*2. The actual palletizing speed depends on the weight, dimensions, and layout of the boxes; single suction cup can achieve 8 boxes per minute, while double suction cups can achieve 12 boxes per minute.		
*3. The dimensions and layout of the boxes may affect the actual palletizing height.		
*4. Excluding the weight of the robotic arm and the end effector.		

Configuration List

Product Name	CR20A Columnar Palletizing Workstation	CR20A Lifting Palletizing Workstation
CR20A Collaborative Robot	✓	✓
Robot Control Cabinet	✓	✓
Palletizing Workstation Base	✓	✓
Lifting Column	-	✓
Fixed Column	✓	-
Palletizing Process Package	✓	✓
Laptop	Optional	
Teach Pendant	Optional	
End-effector Vacuum Gripper	Optional	

